



*World Leader in Rating Technology*

# OFFSHORE RACING CONGRESS



**Standard Sailing Instructions**  
**2019**

# Standard Sailing Instructions Guide

---

## Part 1 - General

### 1 Organizing Authority

The **[insert class and championship]** is organized by the **[insert hosting authority]** in conjunction with **[insert co-organizer, if any]** under the authority of **[insert name of National Sailing Federation]** and under the overall authority of the Offshore Racing Congress (ORC) and the World Sailing (WS).

### 2 Rules

2.1 The regatta will be governed by the rules as defined in The Racing Rules of Sailing (RRS).

2.2 The following rules will also apply:

a) IMS Rule

b) ORC Rating Systems Rule

c) **[insert class]** Class Rules **[for ORC Classes]**

d) World Sailing Offshore Special Regulations

(except for Sportboats, all races will be Category 3 (with or without the liferaft aboard – to be decided by the OA and ORC). For Sportboats, ORC Sportboat Class Rules will apply).

2.3 No national authority prescription will apply (*exceptions can be made only to the rules applying to the sailors from the host country, i.e. national sailing licence*)

**[DP]** 2.4 Under RRS 87, ORC Rule 206 is changed as follows:

a) All sails shall have been measured and stamped by an ORC measurer. During the pre-race equipment inspection, sails will be marked for the event by stamp, sticker and/or inspector's signature.

b) The maximum number of sails shall be as defined in ORC Rule 206 with one additional mainsail allowed. The second mainsail shall have a minimum of one set of reef points. The mainsails may be interchangeable.

c) With the exception of the second mainsail all sails shall be aboard while racing.

d) Sails damaged during the series may be repaired. Sails beyond repair may be replaced with permission of the Technical Committee

*(Note: 2.4 is mandatory for the ORC championships and optional for other events)*

2.5 Minimum crew weight as defined in ORC Rules 102.3 and 200.1(b) shall apply.

2.6 A breach of RRS 48.2 or RRS 49.2 shall not be ground for protest by a boat. This changes RRS 60.1(a).

2.6 If there is a conflict between languages the English text will take precedence.

2.7 Part 2 of the Racing Rules of Sailing is replaced by Part B of the International Regulations for Preventing Collisions at Sea from **[insert date and time]** to **[insert date and time]** local time.

**[DP]** 2.8 Appendix 1 of these SI shall apply for the bow numbers. Protests on the bow numbers can be lodged only by the Race Committee. This changes RRS 60.1(a).

### 3 Classes

3.1 Boats will be divided in Classes according to the Notice of Race requirements as follows:

Class A: 16.500 >= CDL > 11.620

Class B: 11.620 >= CDL > 9.800

Class C: 9.820 >= CDL > 8.600

Classes will have separate starts and separate results.

3.2 Any change to CDL after applying ORC rule 305.2(b) shall not change the class that boat originally entered.

### 4 Notices to competitors

Notices to competitors will be posted on the official notice board(s) located at **[insert location(s)]**. Notices will also be posted on the event website. Failure or delay to post the notice on the event website will not be ground for request for redress by the boat. This changes RRS 60.1(b).

### 5 Changes to Sailing Instructions

Any change to the Sailing Instructions will be posted not later than **[insert time]** before it will take effect, except that any change to the schedule of races will be posted by **[insert time]** hours on the day before it will take effect.

### 6 Signals made ashore

6.1 Signals made ashore will be displayed at **[insert location]**.

6.2 When flag AP is displayed ashore '1 minute' is replaced with 'not less than **[insert number]** minutes' in race signal AP. This changes race signal AP.

### 7 Schedule of races

*(Conforming to paragraph 8 of the NoR)*

7.1 Times of the first warning signals are defined as follows:

**[insert day]**    **[insert date]**    **[insert time]**    **[insert type of race (inshore or offshore)]**

**[insert day]**    **[insert date]**    **[insert time]**    **[insert type of race (inshore or offshore)]**

etc ...

The Organizing Authority and/or the Race Committee reserves the right to modify the above programme according to weather conditions and/or other unforeseen reasons.

7.2 Eight races are scheduled including two offshore races and six inshore races

*Note: For Continental or Regional Championships where a shortened schedule is used:*

*Seven races are scheduled including one offshore race and six inshore races.*

7.3 There will be no more than **[insert number, when appropriate]** races per day. Flag **[insert flag]** displayed on the Finishing line means "There will be one more race after the one in progress." The Warning signal for the next race will be given one minute after lowering flag **[insert flag]** with one sound.

7.4 On the last day of regatta no warning signal will be given after **[insert time]** unless it follows signal of general recall or postponement (Flag AP) of a race whose first warning signal had been made before **[insert time]**.

## 8 Class flag

The Class flag(s) will be **[insert flag]**.

## 9 The Start

9.1 Races will be started in the following class order: **[insert class]**, **[insert class]**. The Warning signal of the following class will be displayed at the earliest at the starting signal for the previous class, and may also be given while other classes are still racing.

*(use this SI only if the fleet is divided in more classes).*

9.2 A boat starting later than **[insert number]** minutes in the inshore races and **[insert number]** minutes in the offshore race(s) after her Start signal will be scored DNS. This changes RRS A4.1.

9.3 After signalling an individual recall, the race committee will attempt to broadcast the sail number, bow number or name of boat that has not started and is identified as OCS on VHF channel **[insert number]**. Delay in the radio broadcast of these calls, or the order in which they are made, or any omission or failure in the emission or reception of these, will not be grounds for a request for redress by the boat. This changes RRS 60.1(b).

## 10 Penalty system

10.1 The penalty for breaking a rule of Part 2 while outside a Zone will be One-Turn penalty – one tack and one gybe. This changes RRS 44.1.

10.2 For the offshore race, RRS 28 is changed as follows:

(a) In rule 28.1, delete the first sentence and replace with:

'A boat shall cross the starting line after having been entirely on the pre-start side at or after her starting signal and sail the course described in the sailing instructions and *finish*.'

(b) In rule 28.2, delete the first sentence and replace with:

'A string representing a boat's track from the time she begins to approach the starting line from its pre-start side to cross it until she *finishes* shall, when drawn taut, ...'

(c) Add new rule 28.3 Penalty:

A boat that does not cross the starting line as required by rule 28.1 will receive the 20% scoring penalty as defined in RRS 44.3. This changes RRS A4 and A5. The scoring penalty shall be divided equally between offshore race 1 and offshore race 2, if offshore race 2 is completed.

10.3 For minor breaches of the Offshore Special Regulations, RRS 55 and any Sailing Instruction marked with **[DP]** the jury may impose any penalty different from Disqualification, or not impose a penalty, at its discretion. The maximum discretionary penalty for the minor infringements of the Offshore Special Regulations will be the scoring penalty of 10% calculated in accordance with RRS 44.3(c).

## 11 Protests and requests for redress

11.1 Protest forms are available at the race office. Protest shall be delivered there within the time limit which shall be:

a) for inshore races: **[insert number]** hours after the last boat has finished the last race of day. The same time limit applies to protests by the race committee and international jury about incidents they observe in the racing area and to requests for redress (except as permitted in c) below). This changes RRS 61.3 and 62.2.

b) for offshore race(s): **[insert number]** hours after protestor's finish. If a boat finishes by night, a protest can be logged from **[insert time]** until **[insert time]** the next day.

- 11.3 Measurement protest by the boat shall not be accepted after **[insert date and time which shall be day before the last day of the championship]**. This changes RRS 60.1(a) and 61.3.
- 11.4 Notice of protests by the Race Committee or the International Jury will be posted on the official notice board to inform competitors under RRS 61.1(b).
- 11.5 Notices to inform competitors of hearings in which they are parties or named as witnesses will be posted:
- a) for windward/leeward races within 30 minutes of the protest time limit
  - b) for the offshore race, within 30 minutes of the finish of all the boats involved in the protest, except that Protest notices will not be posted **[insert day and date of offshore race]** at **[insert time]** until **[insert day and date of offshore race]** at **[insert time]**.
- 11.6 When RRS N1.4(b) is applied the time limit will be 30 minutes after the decision is given.
- 11.7 The decisions of the International Jury will be final as provided in RRS 70.5.

## 12 Scoring

- 12.1 Windward/leeward race results will be determined by corrected times calculated by **[insert scoring method]**.
- 12.2 Offshore race results will be determined by corrected times calculated by **[insert scoring method]**.
- 12.3 The decision on the scoring method and scoring parameters used will be at the sole discretion of the Race Committee and together with length of course, directions of leg and the wind speed will not be grounds for request for redress by the boat. This changes RRS 60.1(b).
- 12.4 The championship is valid if at least 4 inshore races and 1 offshore race or at least 3 inshore races and 2 offshore races are completed. Offshore races shall be not be discarded and 1 discard will be allowed on inshore races if 5 or 6 inshore races are completed.

*Note: For Continental Championships where a shortened schedule as defined above is used: The championship is valid if at least 3 inshore races and the offshore race are completed. One discard will be allowed if 5 races are completed.*

## 13 Safety regulations

- [DP]** 13.1 Boats retiring for any reason in any race shall report to the Race Committee as soon as possible.
- [DP]** 13.2 Any use of the engine for propulsion purposes for rescuing people, giving help or any other reason shall be reported after arrival in written form to the Race Committee stating reasons for such procedure. If a boat does not gain a significant advantage in the race, the International Jury may impose a discretionary penalty.

## 14 Replacement of crew or equipment

- [DP]** 14.1 The Technical Committee may approve crew changes (adding new crew members, replacing or disembarking crew members) by written skipper's request made no later than **[insert number]** hour before the scheduled time of the start of the first race of the day. The substituted crew member shall not be aboard on any other competing boat throughout the remainder of the series. The weight of all crew members on board weighed in light street clothes after all crew changes shall not be greater than the maximum and smaller than the minimum as defined in ORC Rule 200.1. Crew substitutions in Corinthian Division shall also be valid World Sailing group 1 sailors. If not, the entry will be scored in the Open Division.
- [DP]** 14.2 Substitution of damaged or lost equipment will be not allowed unless approved by the Technical Committee. Requests for substitution shall be made to the Technical Committee at the first reasonable opportunity.

## 15 Equipment and measurement checks

A boat or equipment may be inspected at any time for compliance with class rules and Sailing Instructions. On the water or after arriving in harbor, a boat may be instructed by the measurer including VHF channel **[insert channel]** to proceed immediately for inspection.

## 16 Official boats

16.1 Official boats will display an **[insert flag]**. Failure of any official boat to display her flag will not be grounds request for redress by the boat. This changes RRS 60.1(b).

16.2 Vessels used by press, photographers, film crews, VIPs etc. are not under the jurisdiction of the Race Committee. Any action by these boats shall not be ground for request for redress by the boat. This changes RRS 60.1(b).

## [DP] 17 Support boats

Support boats shall be registered at the race office where identification number will be assigned. Identification shall be visible at all times. All support boats shall keep well clear of the starting area and, after the preparatory signal, are not to approach within 100 meters of any competing boat. A breach of this SI may result with a scoring penalty against the boat connected and/or withdrawal of permission to be in the racing area for one or more days.

## [DP] 18 Haul-out restriction

From 09:00 on **[insert first scheduled day of registration]** yachts shall not be hauled out except for the purposes of repairing damage; and only after written permission from the International Jury. While hauled for this purpose, cleaning and polishing of the hull below the waterline will not be permitted. Appendages shall not be removed from the boat during the series.

## 19 Communication

19.1 Radio communication with Race Committee during the regatta will be on VHF channel **[insert number]**. The Race Committee may give verbal confirmation of any race signal over VHF Channel **[insert number]**. Failure to make a broadcast or to time it accurately will not be grounds for request for redress by the boat. This changes RRS 60.1(b).

[DP] 19.2 Except when communicating with the race committee, a boat while racing, shall not transmit or receive communication of any information not publicly available to all boats participating. This changes RRS 41.

## 20 Trophies and prizes

**[insert list of trophies and prizes including Corinthian and Owner/Driver trophies when applied, together with their respective requirements].**

## 21 Disclaimer of liability

Competitors participate in the regatta entirely at their own risk, see RRS 4 - Decision to Race. The Organizing Authority, **[insert club]**, **[insert national sailing federation]**, ORC and any other party involved in the organization of the regatta will not accept any liability for material damage or personal injury or death sustained in conjunction with or prior to, during, or after the regatta. Each boat owner or his representative accepts these terms by signing the entry form.

## Part 2 - Inshore course

(Courses should be designed to provide durations of 1 to 1.5 hours)

### 23 The course

- 23.1 The diagram in Attachment **[insert number]** shows the course, including the approximate angles between legs, the order in which marks are to be passed, and the side on which each mark is to be passed.
- 23.2 No later than the warning signal, the RC signal boat will display the approximate compass bearing of the first leg.

### 24 Marks

- 24.1 Marks **[insert number or letter from diagram]** will be **[insert description]**.
- 24.2 New mark as provided in instruction 25.1 will be **[insert description]**.

### 25 Change of the next leg of the course

To change the next leg of the course, the race committee will lay a new mark and remove the original mark as soon as practicable. A new windward mark will be placed without the offset mark.

### 26 Starting line

The starting line will be between **[insert description]** at the starboard and **[insert description]** at the port-end.

### 27 Finishing line

The finishing line will be between **[insert description]** and **[insert description]**.

### 28 Time limit

The time limit for the first boat to finish will be **[insert time calculated as the length of the course in NM/3]**. Boats failing to finish within **[insert time]** after the first boat sails the course and finishes will be scored Did Not Finish. This changes RRS 35 and A4.

*Note: The time limit after the first boat finishes shall be based on the difference in GPH, or the time allowances at 6 knots, between the slowest and fastest boats, multiplied with an appropriate factor.*

## Part 3 - Offshore course

### 29 The course

The course will be: Start - **[insert marks and side on which have to be left]** - Finish.

### 30 Marks

Marks **[insert number or letter from diagram]** will be **[insert description]**.

### **31 Windward mark**

The RC may set a windward mark to obtain a start to windward, if necessary. If the windward mark is set, it will be approximately one nautical mile from the starting area and the RC will, before the warning signal, display a red flag which indicates the mark shall be left to port, or a Green flag indicating the mark shall be left to starboard.

### **32 Starting line**

The Starting line will be between **[insert description]** at the starboard and **[insert description]** at the port-end.

### **33 Finishing line**

33.1 The Finishing line will be between **[insert description]** and **[insert description]**.

### **34 Time limit**

34.1 There will be no time limit for the first offshore race.

34.2 The time limit for first boat to finish will be **[insert time calculated as length of course in NM/3]**. Boats failing to finish within **[insert time]** after the first boat sails the course and finishes, shall be scored with the number of points equal to the number of boats that have started and finished within the time limit, plus 1. This changes RRS 35 and A4.

*Note: Time limit after first boat finishes shall be based on the difference in GPH, or the time allowances at 6 knots, between slowest and fastest boat in the class or the fleet, multiplied by an appropriate factor.*

### **[DP] 35 Finishing by night**

Boats that finish by night shall illuminate their numbers when finishing, and in case of doubt shall try to identify themselves to the RC after finishing.

### **[DP] 36 Reporting positions**

**[insert requirement for reporting positions including times and mean of communication, if any]**.



## APPENDIX 1 - BOW NUMBERS

Bow numbers shall be placed as forward as possible

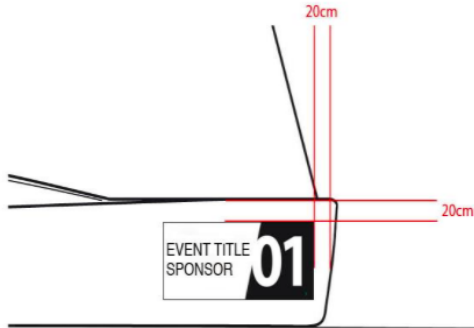

**CORRECT**

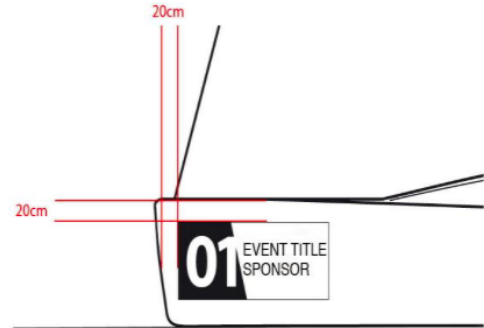

**NOT CORRECT**



Copyright © 2019 Offshore Racing Congress.

Cover picture: Offshore World Championship 2018  
Courtesy Sander van der Borch.